

LEDempire

The new age of lighting

Hi-Slim

LED Street Light

IP67

SEVEN-YEAR

7

WARRANTY



250W 300W

High Performance &
Ultra-thin LED Street Light
Free-tool Maintenance



150W 200W



45W 75W 100W

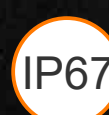

Features

1. Ultra slim heat sink design makes the lamp lighter and better in heat dissipation
2. High lumen SMD3030 chip
3. Waterproof IP67, high thermal conductivity housing
4. Beam angle Type II, III, IV glass lens with transmittance 92%

Tool-free LED Driver Replacement

Independent driver board
easy replacement



With Buckle

Open the cover free-tool



Bubble Level

The level instrument accurates the installation
of lamps in one minute

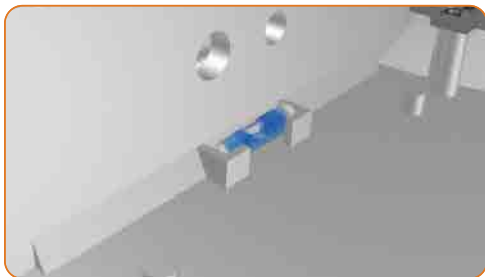

Vent

There are two vents with a balanced atmosphere
Pressure and moisture prevention



Intelligent

- ▶ 0-10V Dimming
- ▶ Timer Control
- ▶ DALI Control
- ▶ Solar Compatible
- ▶ Photocell
- ▶ Occupancy sensor

Features



• Power would automatically be off once the fixture body opened.

• Driver board separately installed on housing, easy for replacement and installation of driver and smart control. The layout with cable is neatly arranged.

• Hidden shaft, conducive to the power cover 0-90 degrees rotation and more beauty for the overall appearance of luminaire.

• Light distribution: Type II III IV

• Buckle for fixing heat sink could be opened without tools.
• There is a supporting bracket to hold upper and lower parts of fixture body, when electricians open for maintaining.

• LED Driver integrated with SPD (surge protection device)

• Support all kinds of intelligent sensors (photocell, PIR sensor, timing, etc)

3030 SMD LED chip, high lumen 150LM/W

Light distribution

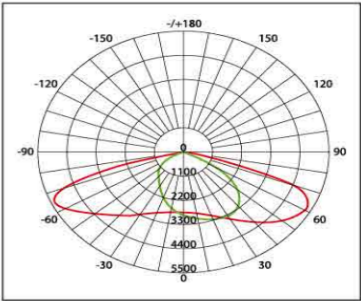
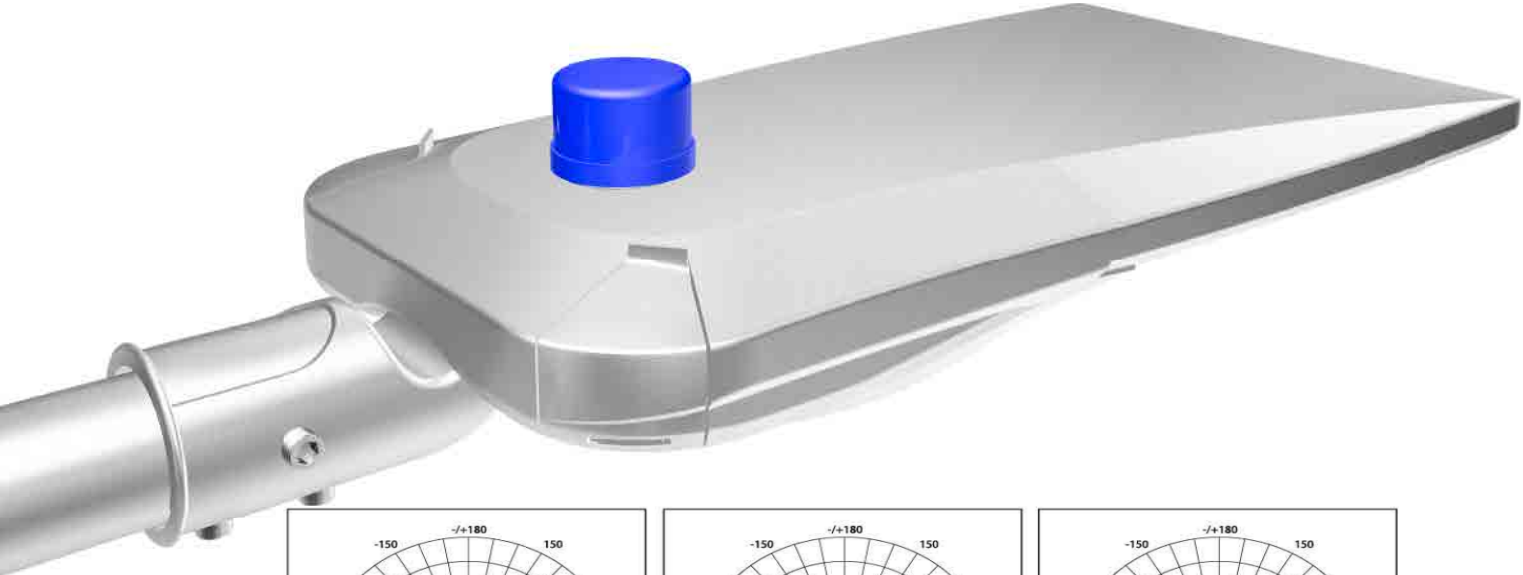

Type II

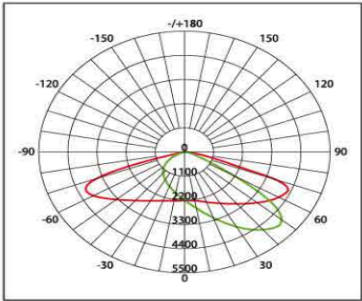

Type III

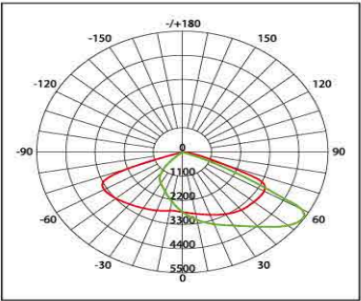

Type IV

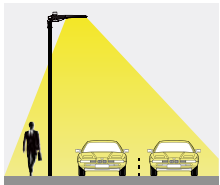
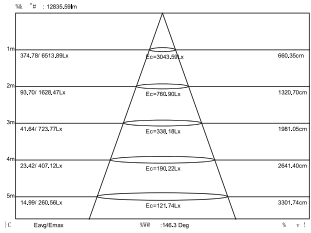

Type II

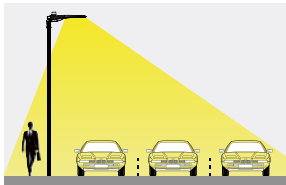
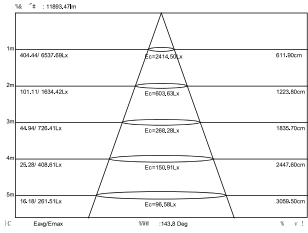

Type III

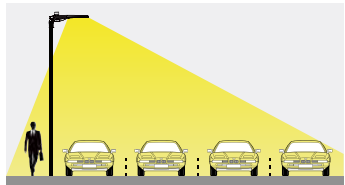
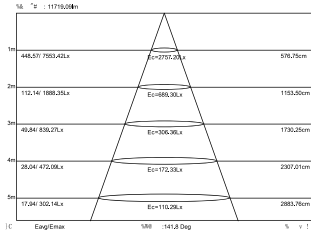

Type IV



45W/75W/100W

SPECIFICATIONS



Technical Data

Model Number	HS-SL45W/75W/100W-B
Power	45W/75W/100W
Luminous Efficacy	150lm/W
Lumen Output	6750lm/ 11250lm/ 15000lm
LED Quantity	77pcs/154pcs/154pcs
Dimension	L378*W280*H82mm
CCT	3000K 4000K 5000K 6000K (Custom Option)
CRI	>70Ra
System Efficiency	≥90%
Lens	Type II, Type III, Type IV

Product Dimensions

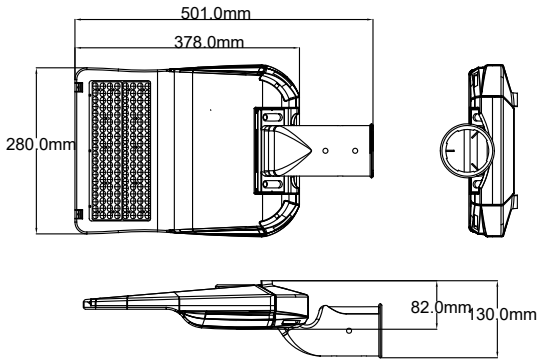

Electrical Details

Input Voltage	AC100-277V/347V/480V
Power Frequency	50-60Hz
Output Voltage	DC36-48V
Power Efficiency	>92%
Power Factor	≥0.95
Total Harmonic Distortion	≤15%
Dimmable	Yes (Optional)

Photometrics

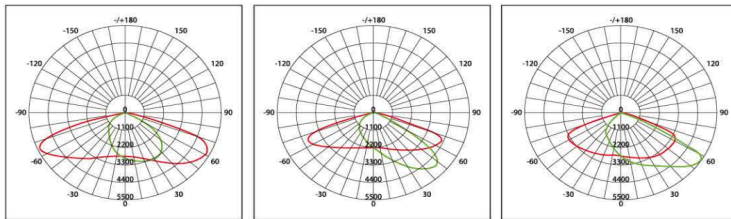

Type II

Type III

Type IV

Other Details

IP Rating	IP67
Lifespan	100,000+ Hours
Storage Temperature	-20°~65°C
Operating Temperature	-20°~55°C
Luminaire Net Weight	5.1KG/5.2KG/5.4KG
Certification	UL,DLC Premium,SAA,TUV,VEET,CB
Color of housing	Gray(customized)

SEVEN - YEAR
7
WARRANTY

150W/200W

SPECIFICATIONS



Technical Data

Model Number	HS-SL150W/200W-B
Power	150W/200W
Luminous Efficacy	150lm/W
Lumen Output	22500lm/30000lm
LED Quantity	231pcs/308pcs
Dimension	L570*W379*H111mm
CCT	3000K 4000K 5000K 6000K (Custom Option)
CRI	>70Ra
System Efficiency	≥90%
Lens	Type II, Type III, Type IV

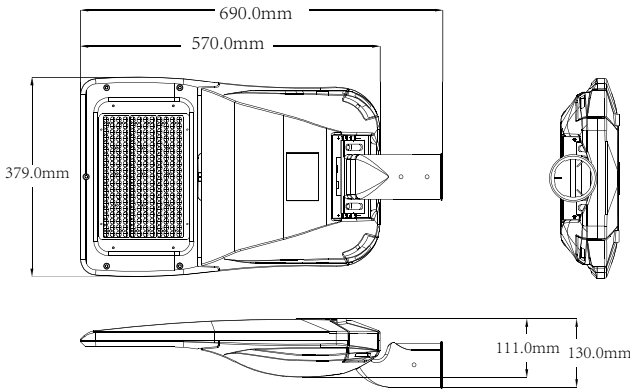

Electrical Details

Input Voltage	AC100-277V/347V/480V
Power Frequency	50-60Hz
Output Voltage	DC36-48V
Power Efficiency	>92%
Power Factor	≥0.95
Total Harmonic Distortion	≤15%
Dimmable	Yes (Optional)

Photometrics

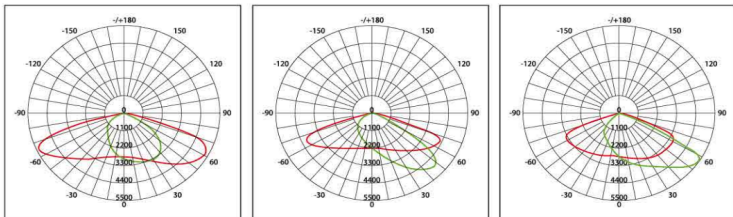

Type II

Type III

Type IV

Other Details

IP Rating	IP67
Lifespan	100,000+ Hours
Storage Temperature	-20°~65°C
Operating Temperature	-20°~55°C
Luminaire Net Weight	10.1KG/10.2KG
Certification	UL, DLC Premium, SAA, TUV, VEET, CB
Color of housing	Gray(customized)

250W/300W
SPECIFICATIONS

SEVEN - YEAR
7
WARRANTY



Product Dimensions

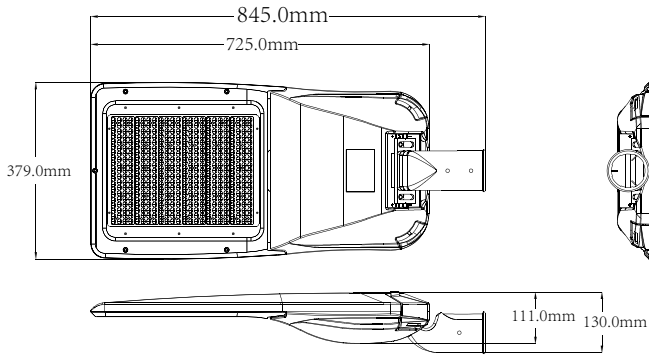

Photometrics

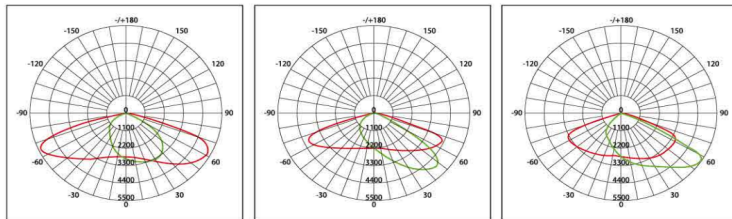

Type II

Type III

Type IV

Technical Data

Model Number	HS-SL250W/300W-B
Power	250W/300W
Luminous Efficacy	150lm/W
Lumen Output	37500lm/45000lm
LED Quantity	385pcs/462pcs
Dimension	L725*W379*H111mm
CCT	3000K 4000K 5000K 6000K (Custom Option)
CRI	>80Ra
System Efficiency	≥90%
Lens	Type II, Type III, Type IV

Electrical Details

Input Voltage	AC100-277V/347V/480V
Power Frequency	50-60Hz
Output Voltage	DC36-48V
Power Efficiency	>92%
Power Factor	≥0.95
Total Harmonic Distortion	≤15%
Dimmable	Yes (Optional)

Other Details

IP Rating	IP67
Lifespan	100,000+ Hours
Storage Temperature	-20°~65°C
Operating Temperature	-20°~55°C
Luminaire Net Weight	13KG/13.1KG
Certification	UL, DLC Premium, SAA, TUV, VEET, CB
Color of housing	Gray(customized)

Installation

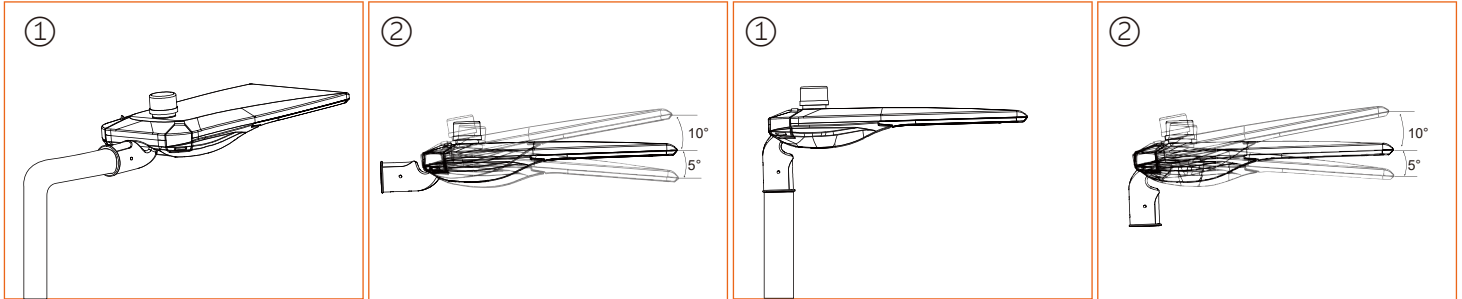

Application



Widely use in high way, parking lot area, roadway, pathway, square, stadium, residential area, yard, industrial area and etc.

Packing Info

Model No.	N.G(KG)	G.W (KG)	Pcs/carton	Carton Size(CM)
HS-SL45W-B	5.1	12	2	58*32*40
HS-SL75W-B	5.3	12.2	2	58*32*40
HS-SL100W-B	5.4	12.5	2	58*32*40
HS-SL150W-B	10.1	18.7	1	77*48*25
HS-SL200W-B	10.2	18.8	1	77*48*25
HS-SL250W-B	13	21.7	1	92*48*25
HS-SL300W-B	13.1	21.7	1	92*48*25

AFTER-SALE SERVICE

LEDempire warrants this hardware products against defects in materials and workmanship under normal use for a period of SEVEN(7) YEARS from the date of purchase. LEDempire provides free repair or replacement within the warranty period. LEDempire shall charge against defects by abnormal storage, usage, connection, or change the structure or any components of the products.

*Damage by thunderstroke over 4KV(L,N against FG) / 2KV (L against N) will not covered by warranty based on IEC61000-4-5.